

TITAN

FORKLIFTS

8 6 6 . 9 1 6 . 5 4 3 8

TITAN E-SERIES

2.0-2.5 TON
ELECTRIC FORKLIFT

AC Drive Curtis Controller

Legendary Titan Quality

Productivity & Reliability

Powerful Performance

Security & Comfort



All Titan Products meet and exceed
ASME B56-1 and CSA B 335 Standards

| | | | | | | | |
|----------------------------|---------------------|--|---------------------------------------|--------------|--------------|---------------|---------------|
| General | 1 | Model | | | FB20 | FB25 | |
| | 2 | Power Type | | | Electric | Electric | |
| | 3 | Rated Capacity | | kg | 2000 | 2500 | |
| | 4 | Load Centre | | mm | 500 | 500 | |
| Characteristic & Dimension | 5 | Lift Height | | mm | 3000-4800 | 3000-4800 | |
| | 6 | Fork Size | LXWXT | mm | 1066-1219 | 1066-1219 | |
| | 7 | Mast Tilt Angle | F/R | Deg | 6°/12° | 6°/12° | |
| | 8 | Front Overhang (Wheel center to fork face) | | mm | 465 | 465 | |
| | 9 | Tread | F/R | mm | 960/950 | 960/950 | |
| | 10 | Ground Clearance (bottom of mast) | | mm | 110 | 110 | |
| | 11 | Fork Spread | Min. / Max. | mm | 240/1020 | 240/1020 | |
| | 12 | Overall Dimension | Length to face of fork (without fork) | | mm | 2400 | 2400 |
| | 13 | | Overall Width | | mm | 1160 | 1160 |
| | 14 | | Mast Lowered Height | | mm | 2070 | 2070 |
| | 15 | | Mast Extended Height (with backrest) | | mm | 4020 | 4020 |
| | 16 | | Overhead Guard Height | | mm | 2240 | 2240 |
| | 17 | Turning Radius (outside) | | mm | 2075 | 2095 | |
| Performance | 18 | Min. Insecting Aisle | | mm | 2250 | 2250 | |
| | 19 | Speed | Travel (empty load) | | km/h | 15 | 15 |
| 20 | Lifting (full load) | | mm/s | 300 | 270 | | |
| Chassis | 21 | Max. Gradeability | | % | 15 | 15 | |
| | 22 | Tire | Front | | | 7.00-12-12 PR | 7.00-12-12 PR |
| 23 | Rear | | | 18x7-8-14 PR | 18x7-8-14 PR | | |
| Power & Transmission | 24 | Wheelbase | | mm | 1510 | 1510 | |
| | 25 | Service Weight | | kg | 4170 | 4410 | |
| | 26 | Motor | ZF Drive Motor (Germany) | | kw | 11 | 11 |
| | 27 | | Lift Motor | | kw | 8.6 | 8.6 |
| | 28 | Battery | Voltage/Capacity | | V/ah | 48/560 | 48/630 |
| | 29 | | Manufacturer (USA) | | V/Ah | CURTIS | CURTIS |
| | 30 | Controller | Type | | L | AC | AC |
| | 31 | Operating Pressure for Attachment | | Mpa | 17.5 | 17.5 | |

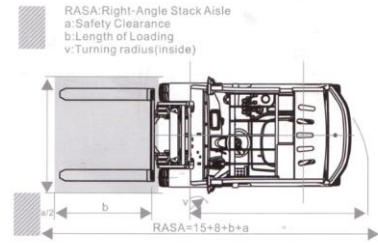
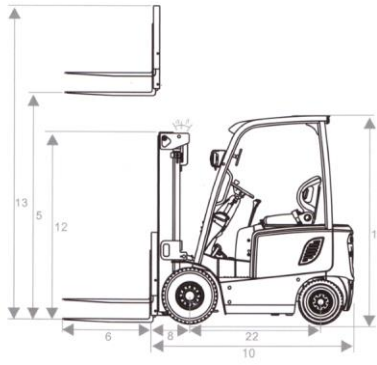
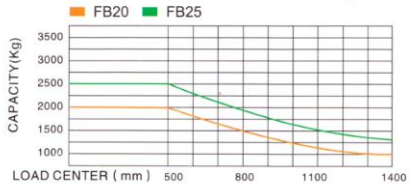

TITAN

FORKLIFTS

Chatham, ON Canada | 866.916.5438

ISO9001
CERTIFIED

ASME
B56.1-2017

SGS
APPROVED

Proud to be your authorized Titan Forklift Representative