

TITAN

FORKLIFTS

www.titanliftrucks.com

8 6 6 . 9 1 6 . 5 4 3 8

TITAN

G-SERIES

3.0-3.5 TON

FORKLIFT

6000 to 8000 LB Capacity

Legendary Titan Quality

Productivity & Reliability

Powerful Performance

Security & Comfort



All Titan Products meet and exceed
ASME B56-1 and CSA B 335 Standards

General	1	Model		FG30	FG35	FG30	FG35		
	2	Power Type		Gas/LPG	Gas/LPG	Gas/LPG	Gas/LPG		
	3	Rated Capacity		kg	3000	3500	3000	3500	
	4	Load Centre		mm	500	500	500	500	
Characteristic & Dimension	5	Lift Height		mm	3000-4800	3000-4800	3000-4800	3000-4800	
	6	Fork Size	LXWXT	mm	1070x125x40	1070x125x50	1070x125x40	1070x125x50	
	7	Mast Tilt Angle	F/R	Deg	6°/12°	6°/12°	6°/12°	6°/12°	
	8	Front Overhang (Wheel center to fork face)		mm	475	480	475	480	
	9	Ground Clearance (bottom of mast)		mm	135	135	135	135	
	10	Overall Dimension	Length to face of fork (without fork)		mm	2730	2770	2730	2770
	11		Overall Width		mm	1225	1225	1225	1225
	12		Mast Lowered Height		mm	2115	2175	2115	2175
	13		Mast Extended Height (with backrest)		mm	4860	4860	4860	4860
	14		Overhead Guard Height		mm	2090	2090	2090	2090
	15	Turning Radius (outside)		mm	2440	2480	2440	2480	
16	Min. Insecting Aisle		mm	2490	2530	2490	2530		
Performance	17	Speed	Travel (empty load)		km/h	19	19	19	19
	18		Lifting (full load)		mm/s	550	520	550	520
	19	Max. Gradeability		%	20	20	20	20	
Chassis	20	Tire	Front		28x9-15-12 PR	28x9-15-12 PR	28x9-15-12 PR	28x9-15-12 PR	
	21		Rear		6.50-10-10 PR	6.50-10-10 PR	6.50-10-10 PR	6.50-10-10 PR	
	22	Wheelbase		mm	1700	1700	1700	1700	
	23	Service Weight		kg	4300	4500	4300	4500	
Power & Transmission	24	Batter	Voltage/Capacity		V/ah	12/80	12/80	12/80	12/80
	25	Engine	Model			K25		3L	
	26		Manufacture			Nissan		GM 3L	
	28		No. of Cylinder			4		4	
	29		Fuel Tank Capacity		L	60	60	60	60
	33	Japanese Transmission	Type			Hydraulic	Hydraulic	Hydraulic	Hydraulic
	34		Stage FWD/RVS			1/1	1/1	1/1	1/1
	35	Operating Pressure for Attachment		Mpa	17.5	17.5	17.5	17.5	

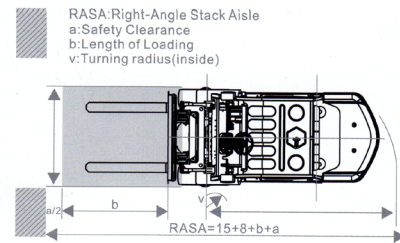
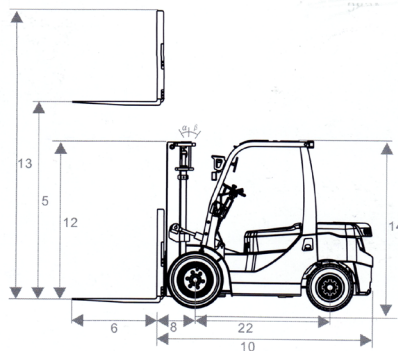
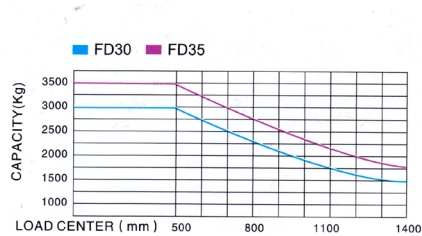

TITAN FORKLIFTS

Chatham, ON Canada | 866.916.5438

ISO9001
CERTIFIED

ASME
B56.1-2017

SGS
APPROVED

Proud to be your authorized Titan Forklift Representative