

"Good design is good business"

- Thomas J. Watson

# TITAN<sup>®</sup>

— F O R K L I F T S —

## 4000 - 5500Lbs

**TE20 (2.0Ton/4400Lbs)**

**TE25 (2.5Ton/5500Lbs)**



### EXPERTISE

Every Titan Forklift is designed, built and supported by a team of dedicated and knowledgeable professionals, each with their own area of expertise. They all work together to deliver a forklift that is of superior quality both in design and function; Engineers, Product experts, ergonomists, and operators and mechanics all come together for one purpose – to bring our products out.

### EFFICIENCY

Titan Forklifts are manufactured using Six Sigma methodologies. Essentially, Six Sigma identifies and removes the causes of defects so as to minimize the "variability in manufacturing and business processes"

- Wikipedia: Six sigma

### EXCELLENCE

At Titan, a commitment to continuous improvement and innovation is a clear indication of our level of performance and operational excellence. It comes from applying the same patience and diligence to everything we do – from seemingly small tasks to large scale projects and investments, it gives us the shortest path from the factory floor to the customers' satisfaction.



## ELECTRIC SERIES



*Designed in Canada with the best components for unsurpassed reliability, by knowledgeable industry Professionals with over 40 years of experience*

Titan Forklifts are built for versatility, reliability and profitability. We understand that timely order fulfillment in today's globally competitive marketplace is crucial for success in any warehouse or shipping environment. The Versatile Electric TE20 (2.0ton/4400 lbs.) and TE25 (2.5ton/5500 lbs.) forklifts with standard pneumatic tire and optional solid or non-marking tire offer the power, performance and productivity capabilities you need to succeed. For heavy-duty lifting indoors or outdoor on uneven terrain, Titan's TE20 & TE25 offer outstanding value.

Titan's quality commitment doesn't end in the design room or on the factory floor. Quality service and maintenance programs are crucial to the long-term performance and ROI of any forklift. All of our forklifts come with a robust 5-Year Warranty so your accounting department can rest easy in the confident knowledge that Titan backs what it sells with one of the most comprehensive warranty programs in the industry.

For more information and pricing on these and other fine products from Titan, please contact your local Titan Forklifts<sup>®</sup> dealer or Account Representative today or call us Tollfree at:

**1.844.93TITAN (1.844.938.4826)**

or email us at:

[info@titanlifttrucks.com](mailto:info@titanlifttrucks.com)

All Titan Products meet and exceed ASME B56-1 and CSA B35 Standards.

General	No.	Model		TE20	TE25		
	1		Power Type		Electric	Electric	
3		Rated Capacity		kg / lbs	2000 / 78.74	2500 / 5511	
3		Load Centre		mm / in	500 / 19.68	500 / 19.68	
Characteristics & Dimension	4	Lift Height		mm / in	3000 - 4800 118.11 - 188.97	3000 - 4800 118.11 - 188.97	
	5	Fork Size	L x W x H	mm / in	1070 x 120 x 40 42 x 7.75 x 1.5	1070 x 120 x 40 42 x 7.75 x 1.5	
	6	Mast Tilt Angle		F/R	Deg	6°/12°	6°/12°
	7	Front Overhang (Wheel center to fork face)			mm / in	465 / 18.30	465 / 18.30
	8	Tread		F/R	mm / in	960 - 950 3779 - 3740	960 - 950 3779 - 3740
	9	Ground Clearance (bottom of mast)			mm / in	110 / 4.33	110 / 4.33
	10	Fork Spread		Min./ Max	mm / in	240 - 1020 9.44 - 4015	240 - 1020 9.44 - 4015
	11	Overall Dimension	Length to face of fork (without fork)		mm / in	2400 / 94.48	2400 / 94.48
	12		Overall Width		mm / in	1160 / 45.66	1160 / 45.66
	13		Mast Lowered Height		mm / in	2070 / 81.49	2070 / 81.49
	14		Mast Extended Height (with backrest)		mm / in	4020 / 158.26	4020 / 158.26
15	Overhead Guard Height		mm / in	2240 / 88.18	2240 / 88.18		
Performance	16	Turning Radius (outside)		mm / in	2075 / 81.69	2075 / 81.69	
	17	Min Insecting Aisle		mm / in	2250 / 88.58	2250 / 88.58	
	18	Speed	Travel (empty load)		kmh / mph	15 / 9.32	15 / 9.32
19	Lifting (full load)		mm/s / in/s	300 - 11.81	300 - 11.81		
Classis	20	Max Gradeability		%	15	15	
	21	Tire	Front			7.00-12-12 PR	7.00-12-12 PR
	22		Rear			18x7-8-14 PR	18x7-8-14 PR
Power & Transmission	23	Wheelbase		mm / in	1510 / 59.44	1510 / 59.44	
	24	Service Weight		kg / lbs	4170 / 9193.2	4170 / 9193.2	
	25	Motor	ZF Drive Motor (Germany)		kw	11	11
	26		Lift Motor		kw	8.6	4
	27	Voltage/Capacity		V/ah	48 / 560	48 / 560	
	28	Control	Manufacturer (USA)			CURTIS	CURTIS
	29		Type			AC	AC
	30	Operating pressure for Attachment			Mpa	17.5	17.5

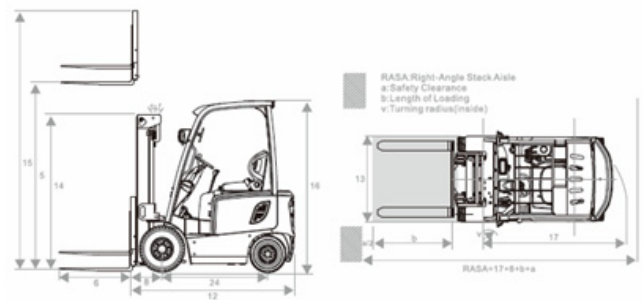
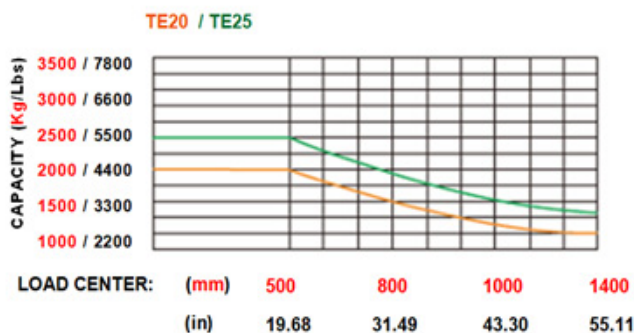

Proud to be your authorized Titan Forklifts Representative

**ISO9001**  
CERTIFIED

**ASME**  
B56.1-2017

**SGS**  
APPROVED

**TITAN**<sup>®</sup>  
- FORKLIFTS -  
QUALITY • RELIABILITY • STRENGTH  
www.titanlifttrucks.com

**Titan Forklifts (2016) Ltd.**  
670 Irwin Street, Chatham, ON. N7M 5J5  
**Telephone:** 1.519.351.9501  
**Tollfree:** 1.844.93TITAN (1.844.938.4826)  
**Email:** info@titanlifttrucks.com

CE  
CERTIFICATION

LIFTING THE FUTURE