

"Good design is good business"

- Thomas J. Watson



EXPERTISE

Every Titan Forklift is designed, built and supported by a team of dedicated and knowledgeable professionals, each with their own area of expertise. They all work together to deliver a forklift that is of superior quality both in design and function; Engineers, Product experts, ergonomists, and operators and mechanics all come together for one purpose – to bring our products out.

EXCELLENCE

At Titan, a commitment to continuous improvement and innovation is a clear indicator of our level of performance and operational excellence. It comes from applying the same patience and diligence to everything we do – from seemingly small tasks to large scale projects and investments, it gives us the shortest path from the factory floor to customers' satisfaction.

COMPONENTS USED IN OUR PRODUCTS



TITAN®

— F O R K L I F T S —

5500Lbs

TG25BCS (2.5Ton/5500Lbs)

TD25BCS (2.5Ton/5500Lbs)

BOX CAR SPECIAL (BCS)

LPG/GAS
OR
DIESEL



Designed in Canada with the best components for unsurpassed reliability, by knowledgeable industry Professionals with over 40 years of experience

Titan Forklifts are built for versatility, reliability and profitability. We understand that timely order fulfillment in today's globally competitive marketplace is crucial for success in any warehouse or shipping environment. The versatile and compact LPG TG25BCS (2.5ton/5500 lbs.) and TD25BCS (2.5ton/5500 lbs.) forklifts with pneumatic tires offer the power, performance and productivity capabilities you need to succeed. For heavy-duty lifting and maneuverability, Titan's TG25BCS and TD25BCS offer outstanding value.

Titan's quality commitment doesn't end in the design room or on the factory floor. Quality service and maintenance programs are crucial to the long-term performance and ROI of any forklift. All of our forklifts come with a robust 5-Year Warranty so your accounting department can rest easy in the confident knowledge that Titan backs what it sells with one of the most comprehensive warranty programs in the industry.

For more information and pricing on these and other fine products from Titan, please contact your local Titan Forklifts® dealer or Account Representative today or call us Tollfree at:

1.844.93TITAN (1.844.938.4826)

or email us at:

info@titanlifttrucks.com

All Titan Products meet and exceed ASME B56-1 and CSA B35 Standards.

General	No.	Model		TD25bcs	TG25bcs	
	1		Power Type		Diesel	Gas/LPG
3		Rated Capacity	kg / lbs	2500 / 5500	2500 / 5500	
3		Load Centre	mm / in	500 / 19.68	500 / 19.68	
Characteristics & Dimension	4	Lift Height	mm / in	3000 - 4800 118.11 - 188.97	3000 - 4800 118.11 - 188.97	
	5	Fork Size	L x W x T	1070 x 120 x 40 42 x 4.7 x 1.5	1070 x 120 x 40 42 x 4.7 x 1.5	
	6	Mast Tilt Angle	F/R	Deg	6°/12°	6°/12°
	7	Front Overhang (Wheel center to fork face)		mm / in	470 / 18.5	470 / 18.5
	8	Ground Clearance (bottom of mast)		mm / in	120 / 4.7	120 / 4.7
	9	Overall Dimension	Length to face of fork (without fork)	mm / in	2439 / 96	2439 / 96
	10		Overall Width	mm / in	1150 / 45.27	1150 / 45.27
	11		Mast Lowered Height	mm / in	2055 / 80.90	2055 / 80.90
	12		Mast Extended Height (with backrest)	mm / in	4860 / 191.33	4860 / 191.33
	13		Overhead Guard Height	mm / in	2070 / 81.49	2070 / 81.49
	14	Turning Radius (outside)		mm / in	2310 / 90.94	2310 / 90.94
15	Min Insecting Aisle		mm / in	2380 / 93.70	2380 / 93.70	
Performance	16	Speed	Travel (empty load)	kmh / mph	19 / 11.80	19 / 11.80
	17		Lifting (full load)	mm/s / in/s	550 / 21.65	550 / 21.65
	18	Max Gradeability		%	20	20
Chassis	19	Tire	Front		7.00-12-12 PR	7.00-12-12 PR
	20		Rear		6.00-9-10 PR	6.00-9-10 PR
	21	Wheelbase		mm/in	1600 / 62.99	1600 / 62.99
	22	Service Weight		kg / lbs	3700 / 8157	3700 / 8157
Power & Transmission	23	Battery	Voltage/Capacity	V/ah	12/800	12/800
	24	Engine	Model		2.4L	K25
	25		Manufacturer		KOHLER*	Nissan*
	26		No. of Cylinder		3	4
	27		Fuel Tank Capacity	Litre / Gal	60 / 15.85	60 / 15.85
	28	Transmission	Type		Hydraulic	Hydraulic
	29		Speed: FWD/RVS		1 / 1	1 / 1
	30		Operating pressure for Attachment	Mpa	17.5	17.5

*Subject to change

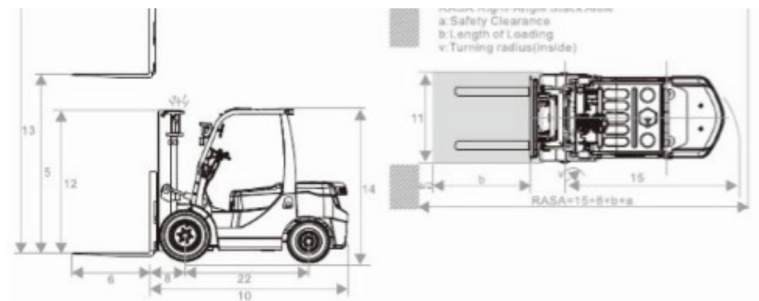
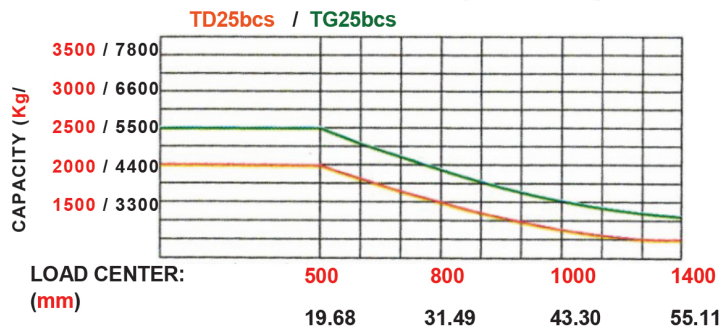

Proud to be your authorized Titan Forklifts Representative

ISO9001
CERTIFIED

ASME
B56.1-2017

SGS
APPROVED

TITAN[®]
- FORKLIFTS -
QUALITY • RELIABILITY • STRENGTH
www.titanliftrucks.com

Titan Forklifts (2016) Ltd.
670 Irwin Street, Chatham, ON. N7M 5J5
Telephone: 1.519.351.9501
Tollfree: 1.844.93TITAN (1.844.938.4826)
Email: info@titanliftrucks.com

CE
CERTIFICATION

LIFTING THE FUTURE